

M. F. THOMPSON & A. L. TOWNSEND.

VOTING APPARATUS.

APPLICATION FILED MAR. 15, 1915.

Patented Mar. 13, 1917.

2 SHEETS—SHEET 1.

1,219,053.

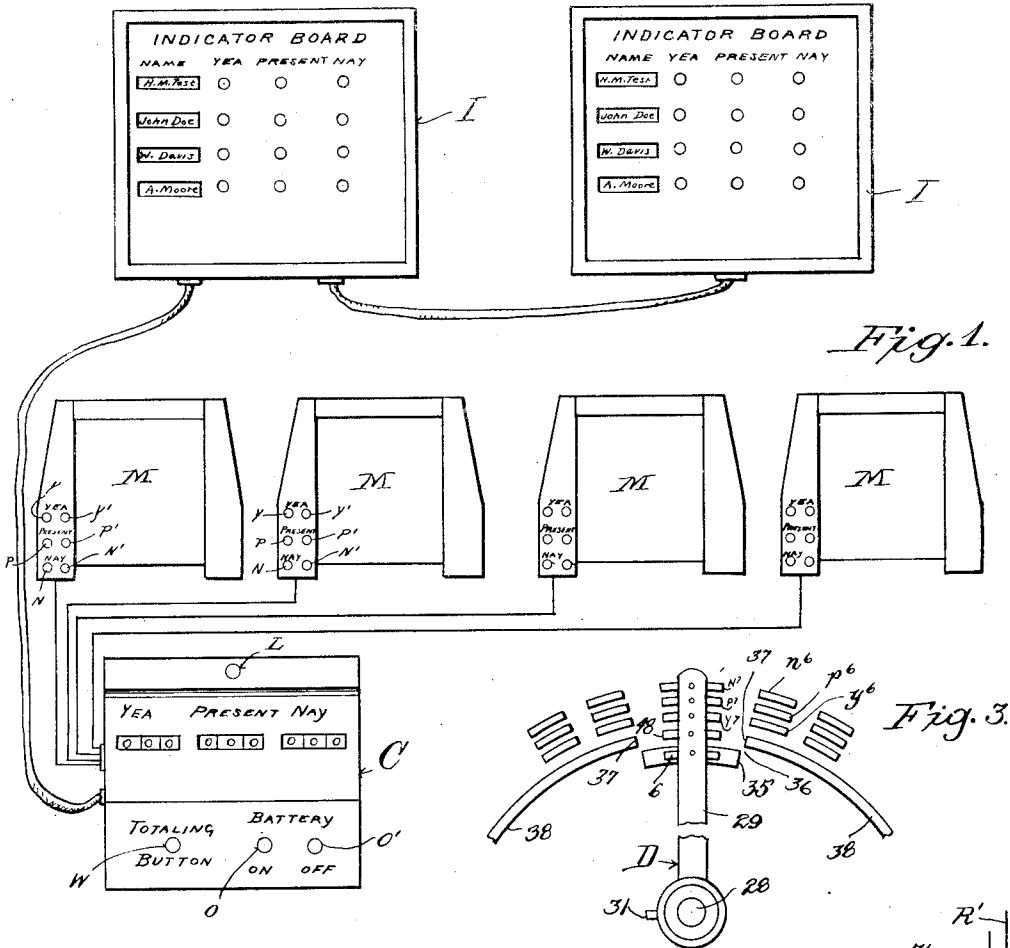

Fig. 1.

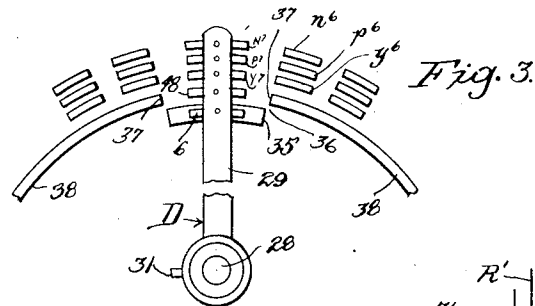

Fig. 3.

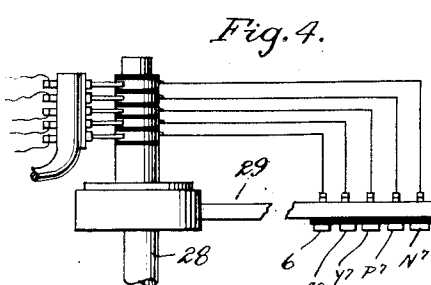

Fig. 4.

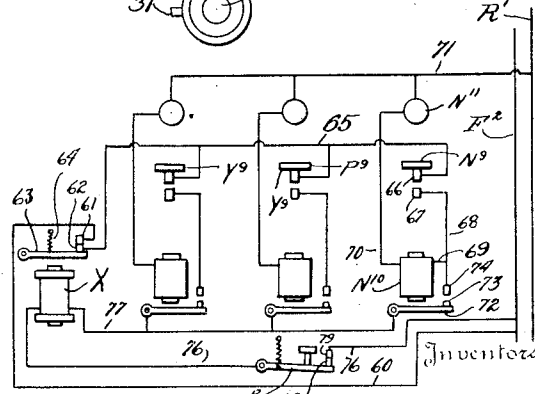

Fig. 5.

Witnesses
J. MacCarty
R. B. Cavanaugh

M. F. Thompson
and
A. L. Townsend
 by *Charles C. ...*
 Attorney

M. F. THOMPSON & A. L. TOWNSEND.
VOTING APPARATUS.

APPLICATION FILED MAR. 15, 1915.

Patented Mar. 13, 1917.

2 SHEETS—SHEET 2.

1,219,053.

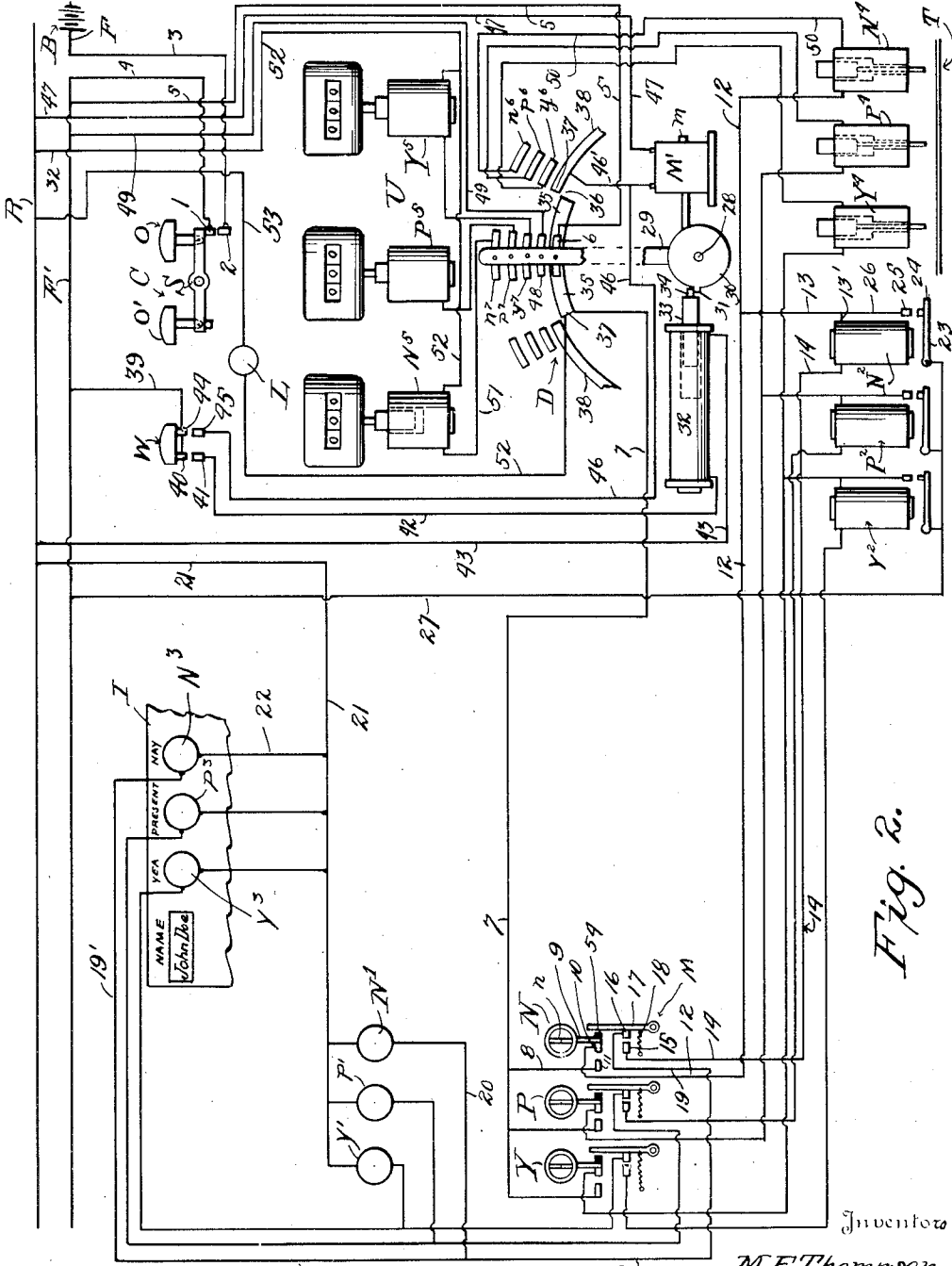

Fig. 2.

Inventors

M. F. Thompson
A. L. Townsend

Witnesses

MacCallister
R. B. Wansgh

Charles *Charles*

Attorney

UNITED STATES PATENT OFFICE.

MARSHALL F. THOMPSON AND ARTHUR L. TOWNSEND, OF WASHINGTON, DISTRICT OF COLUMBIA; SAID TOWNSEND ASSIGNOR TO SAID THOMPSON.

VOTING APPARATUS.

1,219,053.

Specification of Letters Patent.

Patented Mar. 13, 1917.

Application filed March 15, 1915. Serial No. 14,426.

To all whom it may concern:

Be it known that we, MARSHALL F. THOMPSON and ARTHUR L. TOWNSEND, citizens of the United States, residing at Washington, in the District of Columbia, have invented certain new and useful Improvements in Voting Apparatus; and we do hereby declare the following to be a full, clear, and exact description of the invention, such as will enable others skilled in the art to which it appertains to make and use the same.

The present invention relates to certain novel and useful improvements in voting apparatus and is adapted especially for indicating, recording and counting the votes of members of legislative bodies, although we wish it to be understood that it is not limited in its useful application to this particular purpose, as it may be employed in any connection where its use will be found advantageous or desirable.

It is our object to provide an apparatus of this class through the agency of which the members of a voting body may vote simultaneously and their votes visually indicated, and at the end of the period of time, which will hereinafter be termed the voting period, a permanent record will be made of the vote of each member according to its character, and it will be counted according to its character, that is to say whether such member voted "Aye," "Nay" or "Present," or otherwise; and furthermore, such recording, counting and indicating of all the votes is accomplished with extreme rapidity and absolute accuracy.

A further object of our invention is the provision of an apparatus wherein a permanent record of a vote may be made, and during the time such record is being made the individual voting units of the apparatus, or the parts thereof controlled by the individual members, are rendered inoperative so that interference with the recording of the vote through operating the individual units is impossible.

Another object of our invention is the provision of means for visually checking the vote of the member by means of visual indicators, such as small signal lamps, placed in alinement with each voting switch at each member's voting station. Furthermore, visual indicators, such as indicator boards, equipped with electric lamps, may be placed

in any desired place, either in the chamber or at a point distant therefrom, which will indicate how the individual members are voting.

Still another object of our invention is to so construct the apparatus that the act of a member in closing a switch at his designated voting station will not result in immediately recording or counting his vote, but will cause certain mechanism in a central cabinet to be placed in such condition that the subsequent action of the clerk, or person in charge of the cabinet, and designated to operate the apparatus, will then result in the recording and totaling of such vote. Furthermore, in the preferred form of our apparatus a member may, if he so desires, change the condition of the mechanism at the central cabinet during the designated voting period of time, so that the subsequent action of the clerk will cause his vote to be recorded and counted according to the way he last caused the mechanism at the central cabinet to be placed. In other words, a member may change his vote at will during the voting period of time, and when the recording and totaling mechanism is caused to operate his vote will be recorded and counted according to the way he last voted. Furthermore, when a member changes his vote during the voting period of time, he not only changes the mechanism at the central cabinet, but also changes the visual indicators opposite his name at his voting station and on all visual indicators.

It is also our purpose to employ in connection with our apparatus counting mechanism of any improved type which is designed to be actuated to count the number of votes cast and according to the nature of such votes, for instance the total number of "aye" votes and the total number of "nay" votes, and the total number of those voting "Present."

It is also our purpose to provide a simple, efficient, reliable and accurate apparatus of this class which may be manufactured, marketed, installed and operated at a relatively low cost.

With the above recited objects and others of a similar nature in view, our invention consists in the construction, combination and arrangement of parts set forth in and falling within the scope of the appended claims.

In the accompanying drawings:

Figure 1 is a diagrammatic view showing the central station or clerk's desk, the indicator boards and four members' seats, these parts, together with the electric conductors being merely shown conventionally.

Fig. 2 is a diagrammatic view of our apparatus showing the arrangement and location of the apparatus at the clerk's desk or central station and the complete voting apparatus for one member, as well as the electric connections therefor.

Fig. 3 is a view in front elevation of a portion of the split commutator ring and showing the segmental contact plates arranged adjacent thereto, the commutator arm being also illustrated.

Fig. 4 is a view in side elevation of the commutator arm and its shaft as well as the electric connections therefor.

Fig. 5 is a diagrammatic view showing the electric circuit of a modified form of apparatus wherein a breaker relay and an error switch is employed, this modified form being used where it is desired to prevent the member from voting more than once on the same question.

Before entering into a detailed description of our invention, we will briefly state that in the practice of the same we place at each member's seat three switches which may be in the nature of locks, buttons or the like, and at each switch is arranged a small signaling lamp, or other visual indicator adapted to be lighted when the switch is operated by the member in the act of voting. The ornamental cover plate of the switch is marked "Yea", "Nay" and "Present", or otherwise marked as desired, indicating the three kinds of votes, one of these terms, of course, applying to each switch. The lamp which is lighted corresponds to the switch operated. At the clerk's desk, or at any other suitable location in the hall or chamber, or elsewhere, is provided a cabinet which contains the vote recording device, in the present instance card punching machines and the counting devices, these latter being of any suitable nature. We also provide one or more indicating boards, each board having vertical columns sub-divided into spaces, each space being adapted to contain the name of the member of the voting body, and opposite each name we arrange in a horizontal line three signal lamps, or other visual indicator, also indicated by the words "Yea" "Nay" and "Present", these words corresponding to the designations referred to as placed at the member's seat, desk or voting station. Now, when a vote is to be taken a member closes the switch at his voting station by depressing the button or turning the lock, depending on the character of the switch. For instance, if a member desires to vote "Yea", he closes the "yea"

switch, and this causes the lamp under the word "Yea" or the indicator board to indicate that the member has voted "Yea". and at the same time the "yea" signal lamp at the member's desk or seat will also be lighted, calling his attention to the manner in which he has voted. But at the same time the vote is not recorded or counted, but is merely indicated, as such recording or counting is accomplished through the operation of certain mechanism by the clerk. Therefore, during a certain period, which we have heretofore called the voting period, and which may be, for instance, five minutes, the vote is simply indicated on the indicator board and at the member's desk or seat through the agency of the signal lamps or other visual indicators. When all the members have voted, or when the period of five minutes for voting has terminated the clerk at his desk or at the cabinet closes a switch, which is hereinafter called the totaling switch, and this will result in placing in operation mechanism hereinafter described which will cause the recording machine at the cabinet to record the vote of each member, and at the same time will operate totaling counters so that the total number of votes taken will be shown.

After the recording and counting of the vote has been completed, the clerk may restore the individual voting units to their original positions, ready for the taking of the next vote, as hereinafter described, at the same time extinguishing the indicating lamps at the boards and signal lamps at the desks or seats of the members, by opening for a moment the current supply switch.

In the preferred form of apparatus, during the voting period above referred to, should a member desire to change his vote, he may do so, as above mentioned, but in one modified form of the apparatus which is herein shown, when a member has once voted he cannot change such vote by manipulating his individual unit, but must first obtain permission of someone in authority who will actuate certain mechanism to restore the individual voting unit of the member to its original position in order to enable such member to vote according to his desires.

Referring now to the accompanying drawings in detail, the letter C indicates conventionally the clerk's desk or central station at which is located certain mechanism, such as the counting devices, the recording mechanism, and certain controlling apparatus, as will be hereinafter described in detail. The letter I designates an indicator board, which may be located in the assembly chamber at any suitable place, and is merely herein conventionally illustrated, while the letter M designates a member's chair or seat. In

Fig. 1 we have merely shown diagrammatically and conventionally these parts, and have simply indicated conventionally the conduits for the electric conductors. At the member's station we place, in the present instance, three voting switches or buttons, each of which is adapted to be turned with a key. These switches are designated by the letters Y, P and N, and are to enable a member to vote "Yea", "Present" and "Nay" respectively, and if desired, these words may be marked adjacent the respective buttons. Each member's switch has located adjacent thereto a small signal lamp, these signal lamps being indicated by the characters Y', P' and N', respectively.

It will, of course, be understood that each member's station or seat is equipped with three of these switches, and that the system or apparatus may be made to accommodate any number of members constituting the assembly or voting body. In order to give a clear understanding of the invention, however, we have in Fig. 2 of the drawings shown the complete system of one member's station, as well as the equipment at the clerk's desk operating in conjunction therewith, and in describing our apparatus we will, by way of example, recite the operation which takes place when a member votes on a question. In this example we will assume, for instance, that a member desires to vote "Nay." The apparatus is provided with the electric power from a suitable battery B, having the main feed conductor F, and the main return conductor R. At the clerk's desk is a main battery switch S equipped with the "on" button O and the "off" button O'. This switch S has a contact 1, which when the "on" button O is depressed, is adapted to close the main circuit to the battery through the contact point 2 so that current will pass from the main feed conductor F, through the conductor 3, contact 2, contact 1, and conductor 4, flowing thence along the feed conductor F', which feeds current to all of the members' stations, the return R being common to all of the stations. When the battery circuit is thus closed by moving the switch S to "on" position, and current is flowing through the main feed conductor F', current will pass through the branch conductor 5, to the contact brush 6 of the commutator D which is at the clerk's desk, and thence through the segmental contact plate 35 and conductor 7 to the branch wire 8 of the switch N at the member's station or seat, this switch N being, as explained, for voting "Nay." Now, should the person at the member's station insert a key in the slot *n* of the switch N and turn the same to the left, he will turn the switch arm 9 toward the left and bring the contact block 10 of this arm into contact with the stationary contact block 11.

The result is that the current may pass from the wire 8, through the contact block 11, and contact block 10 to the conductor 12, and through this conductor back to the clerk's station C, the current at the clerk's desk passing through the branch wires 13 and 13' to the locking relay N², there being, of course, three of these relays indicated at Y², P² and N², respectively, these three locking relays being for the "yea," "present" and "nay" voting switches of the member. As in the example given, where the member is presumed to vote "nay," the current will, as stated, pass through the branch wires 13 and 13' to the relay magnet N². From this magnet N² the current passes through the conductor 14 back to the member's station M, where this conductor is connected with the stationary contact block 15. Normally in contact with this block is a second contact block 16 carried by the pivoted armature 17, the spring 18 normally holding the contact 16 in engagement with the contact 15. The current flowing from the conductor 14 passes through these contacts 15 and 16 and through the conductor 19 to the wire 20, a portion of the current flowing through this wire 20 to the "nay" lamp N' at the member's desk lighting the latter, the current passing from the lamp through the conductor 21 and thence to the return R. A portion of the current also passes through the conductor 19' to the "nay" lamp N³ on the indicator board, lighting this lamp N³, and passes from the lamp through the wire 22 to the conductor 21 through which it flows to the return R. Thus it will be seen that when the person voting operates the switch N by means of a key as just described, he will light both his "nay" signal light N' and the "nay" signal lamp N³ on the indicator board. Of course, the member is not supposed to keep his key in the voting switch N to maintain the same in circuit closing position, and consequently when the electric circuit, just described, is completed by the member turning the switch by means of the key, the locking relay N² is energized by the current passing through, and the armature 23 is drawn toward the magnet. This armature carries at its free end a contact plate 24 which is brought into contact with the contact plate 25 of the conductor 26. With the closing of the contact 24 against the contact 25, the current will pass from the main feed F, through the closed switch S, to the main feed conductor F', thence through the conductor 27, to the armature 23, through the contacts 24 and 25, to the conductor 26, wire 13', through the relay magnet N², through the conductor 14, contacts 15 and 16, and conductor 19, and thence through the conductors 20 and 19', to the lamps N' 130

and N^3 , respectively, and thence through the conductors 21 and 22 to the return R. It will thus be seen that when the person voting, after momentarily turning the switch lock N withdraws his key therefrom so that the contact between the contact blocks 9 and 11 is broken, the lamp N^1 at the member's station, and the lamp N^3 on the indicator board will remain lighted because the lighting circuits thereof remain closed at the contacts 24 and 25. Y^3 , P^3 and N^3 are indicator board lamps.

When these lamps are lighted, however, as just described, the member's vote is not recorded or counted, but is merely indicated by the light at his voting switch and by the light on the indicator board, and this condition will prevail throughout the period allowed for voting, which may be, for instance, five minutes.

In order to record the votes, we provide at the central station or clerk's cabinet, a recording mechanism for each member. In the present instance we have shown the recording mechanism of one member or voter, which mechanism in this case is in the nature of a card or sheet punching machine, operated by solenoids, and is indicated as an entirety by the letter T. The punching mechanism of each member consists of three solenoid punches Y^4 , P^4 and N^4 for punching and indicating the "yea" vote, "present" vote and "nay" vote, respectively. The three solenoids are arranged so as to occupy the smallest possible space, and are so constructed that when an electric impulse is sent through any one of the solenoids, and the latter is consequently energized, as hereinafter described, the plunger of the solenoid which carries a cutter, will project the latter through a card or sheet of paper properly inserted therebeneath. Each punching solenoid is in an auxiliary circuit so that the record is made from a measured impulse from which the human factor is entirely eliminated.

At the clerk's desk or central station we also provide counting mechanism indicated as an entirety by the letter U and which is employed for counting and totaling the vote of the entire voting body. In the present instance this counting mechanism includes three solenoid operated adding or counting devices of any suitable form, and in this connection we wish it to be understood that we may employ any type of adding machine or counting mechanism which is applicable to our purpose. The counting device Y^5 is for counting and totaling the "yea" votes, the counting device P^5 is for counting and totaling the "present" votes, and the counting device N^5 is for counting and totaling the "nay" votes.

The counting mechanism and the recording mechanism are controlled and operated

at the clerk's desk or station by means of a switch W which in the present instance is in the nature of a push button. Controlled by this switch W, and located at the clerk's station is a motor M' , the shaft m of which meshes with or is geared to the shaft 28 of the commutator arm 29. This arm is provided with a disk-like head 30 having a locking lug 31 extending from the periphery thereof, while 32 designates a solenoid trip magnet, the plunger 33 of which is provided with a locking lug 34, which, when the magnet 32 is deenergized, is adapted to interlock with the lug 31 of the head of the commutator arm when the latter is positioned therebeneath, as when the brush 6 of the arm rests on the segmental contact strip 35 which occupies the space 36 between, but out of contact with the ends 37 of the split commutator ring 38. Surrounding this split commutator ring are three rows of segmental contact plates. One row is made up of the plates y^6 , which are brought into operation as hereinafter described when recording and counting the "yea" votes of the members, the plates of the second row are shown at p^6 , and are likewise used in the recording and counting of the "present" votes, while the third row of plates shown at n^6 , are used in recording and counting the "nay" votes. Each member has his voting unit or apparatus electrically connected with one plate of each kind, that is, with one of the plates y^6 , one of the plates p^6 , and one of the plates n^6 , and each member's set of plates, as will be seen by reference to the drawings, is arranged in radial alinement relative to the commutator ring 38. Now, when the clerk closes the switch button W, as hereinafter described, the trip magnet is energized so that the locking plunger thereof is withdrawn or released from interlocking engagement with the commutator arm, and the motor is energized so that the commutator arm is caused to travel over these segmental plates y^6 , p^6 and n^6 , and will also travel in contact with the split commutator ring 38. The result will be that as the traveling commutator arm contacts with the individual segmental plates, circuits will be closed through these plates to the respective recording and counting devices, and the members' votes will be recorded and counted. This operation in detail is as follows:

When the clerk closes the button switch W, current will pass from the main feed line F' , through the conductor 39 to the contact 40 of the button switch, thence to the contact 41, and through the conductor 42, to the trip magnet 32, and from the trip magnet 32 through the conductor 43 to the return wire R. The magnet is thus energized, and the locking plunger 33 thereof drawn inward to release the commutator

arm. With the closing of the switch W current flowing to the switch through the conductor 39 also passes through the contact 44 of the switch, to the contact 45, and
 5 thence through the conductor 46 to the motor M', and from the motor through the conductor 47 to the return R, thus completing a temporary motor circuit. When this occurs, the motor being energized, the shaft *m* thereof is rotated and the rotation of the commutator arm begins, this arm traveling from the left to the right, or clockwise. In its movement the commutator arm 29, with its brush 6, leaves the segmental contact strip 35, while the brush 48 of this arm moves onto the commutator ring 38. This commutator ring 38 is at this time alive or energized by the current flowing from the motor lead 46, through the branch conductor 46' to the ring, the circuit, of course, being closed by the closing of the switch button W. When the commutator arm reaches the commutator ring, so that the brush 48 is brought into contact with this
 10 ring, the clerk may release the pressure on the button switch W and permit the latter to open, because the motor circuit will now be closed from the feed line F', through the conductor 49, brush 48, commutator ring 38, conductor 46', through the motor M', and through the conductor 47 to the return R. Thus it will be seen that the clerk need only momentarily depress the button to start the motor, for when once the brush 48 has contacted with the energized commutator ring 38, the working circuit for the motor will be established and the temporary circuit controlled by the button W may be broken by the clerk releasing the pressure on the
 15 button.

This commutator arm is also provided with three brushes *y*⁷, *p*⁷ and *n*⁷, which are adapted to contact with the rows of segmental contact plates *y*⁶, *p*⁶ and *n*⁶ respectively. Now, for instance, in the example given, where the member has voted "Nay," as the brush *n*⁷, on the commutator arm comes into contact with the segmental contact plate *n*⁶, electric circuits will be completed to the punching or recording device N⁴, and the counting device N⁵ to operate these two devices. That is to say, as heretofore mentioned, the current which passes from the main feed line F' through the conductor 27, armature 23, contact blocks 24 and 25, conductor 13, conductor 12 to the solenoid magnet of the punch N⁴, will pass through this magnet, to and through the conductor 50, to the corresponding segmental contact plate *n*⁶, and thence through the brush *n*⁷, and through the conductor 51 to the solenoid magnet of the counting device N⁵, energizing the latter, and moving the counting mechanism one step, the current
 20 passing from the magnet of the counting

device N⁵ through the conductor 52 to the return R, thus completing the circuit. The result will be that both the punching device N⁴ and the counting device N⁵ are energized, and the punch *n*⁴ of the punching or recording device will punch the proper place to register a "nay" vote on a card or sheet to be placed beneath the same, while likewise, the plunger of the counting device N⁵ will be operated to move the counting mechanism to register one "nay" vote. Of course, the instant the brush *n*⁷ moves off of the contact plate *n*⁶, the circuits to the punching or recording devices N⁴ and to the counting device N⁵ are broken, and these devices are restored to their normal inoperative positions. Thus it will be seen that the member's vote is counted and recorded, while the indicating or signaling lamp N' at his desk continues to remain lighted as does the indicator lamp N³ opposite his name on the indicator board.

The letter L indicates a pilot light at the clerk's desk, and so long as the switch S is closed, and the brush 6 of the commutator arm 29 is in contact with the segment plate 35, this lamp L will remain lighted, for the current will pass through the conductor 5, brush 6, segment plate 35, conductor 52, lamp L, and conductor 53 to the return wire R. The instant, however, that this arm 29 starts on its travel over the split commutator ring 38, and the switch leaves the segment plate 35, this lamp will be extinguished, for its circuit will be opened, but when the commutator arm has completed its travel over the split commutator ring 38, so that the brush 6 again contacts with the segment plate 35, the lamp circuit will be reestablished and the lamp L lighted. This pilot light is to indicate to the clerk the starting and completion of the recording and counting operations, for the lamp is not lighted during the recording and counting.

After all the votes have been recorded and counted, the signal lights at the members' seats or desks, and the indicator lamps on the indicator board are extinguished, and in fact the whole apparatus restored to its normal position ready for the next voting period, by the act of the clerk in opening the switch S, thus breaking the main circuit from the battery B.

It may be that during the voting period or before the clerk operates the button switch W to total and record the votes, a member who has voted "Nay," as just described, may desire to change his vote to "Yea," for example. This he may do by again inserting his key in the slot *n* of his switch N and turning the switch so that the lug 54 at the end of the arm 9 will strike the armature 17 and move the latter outward to the right, thus breaking the engagement of the contact blocks 15 and 16 at the "nay" voting

switch of the member. This will result in the magnet N² of the locking relay being de-energized, so that the pivoted armature 23 will drop, thus breaking the engagement between the contacts 24 and 25 at the relay, 5 thereby opening the member's voting circuit and extinguishing the signal lamp N' at the member's desk or seat, and likewise the indicating lamp N³ on the indicator board. In other words, the member's voting 10 circuit is broken by disengaging the contacts 15 and 16 at the member's voting switch. The member may now withdraw the key from the switch N, and the spring 18 will draw the pivoted armature 17 back 15 again to bring the contacts 15 and 16 into engagement. The member may now insert his key in the switch Y, or that switch for voting "yea," and vote precisely as heretofore described for the "nay" switch N. In 20 this case, however, of course, the "yea" vote will be indicated, recorded and registered.

To prevent a member voting more than one way on the same question, the modified 25 construction shown in Fig. 5 may be employed. In this case a breaker relay X is included in the locking circuits of the three switches of the member's voting unit. In this case the main feed wire is shown at F² 30 and the main return at R'. When one of the member's switches, for instance, the switch N⁹, used for voting "nay," is closed, the current will pass from the main feed wire F², through the conductor 60 to the contact 35 plate 61, which is normally in engagement with the contact plate 62 on the pivoted armature 63, the spring 64 holding the two contact plates in engagement. Current passing through the two engaging plates will 40 flow along the conductor 65 to the member's "nay" switch N⁹, and when the latter is depressed the contact block 66 thereof will engage with the contact block 67, so that the current may pass through the conductor 68 45 and conductor 69 to the locking relay N¹⁰, energizing the latter, the current then passing from the magnet of the relay N¹⁰ through the conductor 70, and the member's lamp N¹¹ to the conductor 71 and so to the 50 return R'. When the relay N¹⁰ is energized the pivoted armature 72 thereof is attracted so that the contact plate 73 of the armature is brought into contact with the contact plate 74 at the end of the conductor 68. The result is that although the member may immediately 55 release the button switch N⁹ to permit the latter to open, the current will pass from the main conductor F² through the conductor 76 and through the normally closed error switch N¹² thereof at the clerk's desk, the current passing from the conductor 76 through the breaker relay X energizing the latter and attracting the armature 63, thus breaking the engagement between 60 the contact plates 61 and 62. From the

breaker relay the current passes through the conductor 77, armature 72, contacts 73 and 74, which are now in engagement, conductor 68, conductor 69, the locking relay N¹⁰, conductor 70, lamp N¹¹ and conductor 71 to 70 the return R'. Of course, when the contacts 61 and 62 are out of engagement, the battery circuit to the member's switch is broken, and although the member may depress the switch it will not perform any function. 75 That is to say the member cannot vote again. In order to enable a member to correct his vote he will have to go to the clerk at the central station, and the clerk may then open the error switch N¹² by depressing the latter 80 so as to move the contact block 78 of the switch out of engagement with the contact plate 79, thereby opening the battery circuit to the breaker relay and consequently to the locking relay N¹⁰, deenergizing these two 85 relays and permitting their respective armatures to drop back to normal inoperative position, thereby putting the member's unit or apparatus in condition for voting.

While we have herein shown and de- 90 scribed the preferred embodiment of our invention, we wish it to be understood that we do not limit ourselves to all the precise details of construction herein set forth by way of illustration, as modification and va- 95 riation may be made without departing from the spirit of the invention or exceeding the scope of the appended claims.

Of course, it will be understood that the system may be enlarged by the addition of 100 voting units to any extent desired, and that furthermore, the recording and counting devices may be of any character desired. Furthermore it will be understood that when desired votes may be indicated and 105 counted without recording, or may be simply indicated without either recording or counting. Of course, the various circuits and parts of the apparatus may be varied in their construction and arrange- 110 ment to suit the particular conditions under which the device is to be used.

What we claim is:

1. In a device of the kind described, a primary circuit including a voter's circuit 115 closer, a visual signal and a relay magnet, a secondary circuit closed by the energization of said magnet and including said visual signal, and vote recording means operable by said secondary circuit. 120

2. In a device of the kind described, a primary circuit including a voter's circuit closer, a visual signal and a relay magnet, a secondary circuit closed by the energization of said magnet and including said visual 125 signal, said secondary circuit also including a secondary magnet and vote recording means operable by the closing of said secondary circuit.

3. In a device of the kind described, a pri- 130

mary circuit including a voter's circuit closer, a visual signal and a relay magnet, a secondary circuit closed by the energization of the relay magnet, vote recording means operable by the closing of the secondary circuit and means adjacent the voter's circuit closer to break the secondary circuit.

4. In a device of the kind described, a primary circuit including a voter's circuit closer, a visual signal and a relay magnet, a secondary circuit closed by the energization of said magnet and including said visual signal, vote recording means operable by the closing of the secondary circuit, a totalizing device connected to the vote recording means, and means adjacent the voter's circuit closer to break the secondary circuit.

5. In a device of the kind described, a primary circuit including a voter's circuit closer, a visual signal and a relay magnet, a secondary circuit closed by the energization of the magnet, vote recording means operable by the closing of the secondary circuit, and means out of control of the voter to break said primary circuit.

6. In a device of the kind described, a primary circuit including a voter's circuit closer, a visual signal and a relay magnet, a secondary circuit closed by the energization of said magnet and including said visual signal, vote recording means operable by the closing of the secondary circuit, a totalizing device connected to the vote recording means, and means out of control of the voter to break said primary circuit.

7. In a voting apparatus, a primary circuit, a central station and a voting station, a member's switch at the voting station adapted to close the primary circuit, a visual signal in the primary circuit adapted to be displayed on the closing of said circuit, a relay in the primary circuit energized on the closing of the latter, a secondary circuit closed when the relay is energized to maintain the circuit closed to the signal after the member's switch has been opened, vote recording mechanism, an electric circuit in which the recording mechanism is located, and a switch at the central station adapted to close the circuit through the recording mechanism to actuate the latter.

8. In a voting apparatus, a primary circuit, a central station and a voting station, a master switch for closing the primary circuit at the central station, a member's switch for closing the primary circuit at the voting station, a visual signal in the primary circuit adapted to be displayed upon the closing of said circuit, a locking relay in the primary circuit energized on the closing of the latter, a secondary circuit closed when the relay is energized to maintain the signal displayed after the member's switch has been opened, a vote recording

device for the member located at the central station, an electric circuit in which the vote recording device is located, a switch at the central station adapted to close the circuit through the recording mechanism to actuate the latter and record the member's vote, a counting device at the central station, and means for actuating the counting device simultaneously with the recording device.

9. In a voting apparatus, a primary circuit, a central station and a voting station, a master switch for closing the primary circuit at the central station, a member's switch for closing the primary circuit at the voting station, a visual signal in the primary circuit adapted to be displayed upon the closing of said circuit, a locking relay in the primary circuit energized on the closing of the latter, a secondary circuit closed when the relay is energized to maintain the signal displayed after the member's switch has been opened, a vote recording device for the member located at the central station, operating mechanism for the recording device, an electric circuit in which the operating mechanism is located, a switch at the central station adapted to close the circuit for the operating mechanism to complete a circuit through the recording mechanism to actuate the latter and record the member's vote, a counting device at the central station, and means for actuating the counting device simultaneously with the recording device.

10. The combination with a main circuit, of a central station and a voter's station in the main circuit, a visual indicator, a switch at the voter's station adapted to be closed to close the main circuit and display a signal at the visual indicator, a locking relay in the main circuit and energized on the closing thereof, a secondary circuit closed when the relay is energized, recording mechanism at the central station, an electric circuit in which said recording mechanism is located, a motor, a motor circuit, means at the central station for closing the motor circuit to energize the motor, and mechanism actuated by the motor adapted to close the electric circuit through the recording mechanism to actuate the latter.

11. The combination with a central station and a plurality of voters' stations in primary electric circuit therewith, a common visual indicator for the voters, means at each voter's station adapted to be operated to display a corresponding signal at the visual indicator, a vote recording device for each voter located at the central station, a secondary electric circuit in which said vote recording devices are located, said secondary circuit being closed by the closing of the primary circuit, a motor, and means common to all the vote recording devices adapted to be actuated when the motor is

energized to cause the operation of the recording devices.

12. The combination with a central station and a voter's station electrically connected therewith, a visual indicator for the voter, a switch at the voter's station adapted to close a secondary circuit and to display a signal at the visual indicator, means at the switch adapted to be operated to break the secondary circuit and restore the signal to its normal position, vote recording mechanism located at the central station, and means at the central station adapted to actuate the vote recording mechanism.

13. In a voting apparatus, a primary circuit, a central station and a voter's station, a member's switch at the voter's station adapted to close the primary circuit,

a visual signal in the primary circuit adapted to be displayed on the closing of said circuit, a relay in the primary circuit energized on the closing of the latter, a secondary circuit closed when the relay is energized to maintain the circuit closed to the signal after the member's switch has been opened, and means adapted to be operated by the member's switch for breaking the secondary circuit to restore the signal to normal inoperative position.

In testimony whereof, we affix our signatures, in the presence of two witnesses.

MARSHALL F. THOMPSON.

ARTHUR L. TOWNSEND.

Witnesses:

RICHARD B. CAVANAY,
CALVIN T. MILANS.