

B. L. BOBROFF.
 SYSTEM FOR SIGNALING.
 APPLICATION FILED APR. 2, 1918.

1,367,583.

Patented Feb. 8, 1921.

3 SHEETS—SHEET 1.

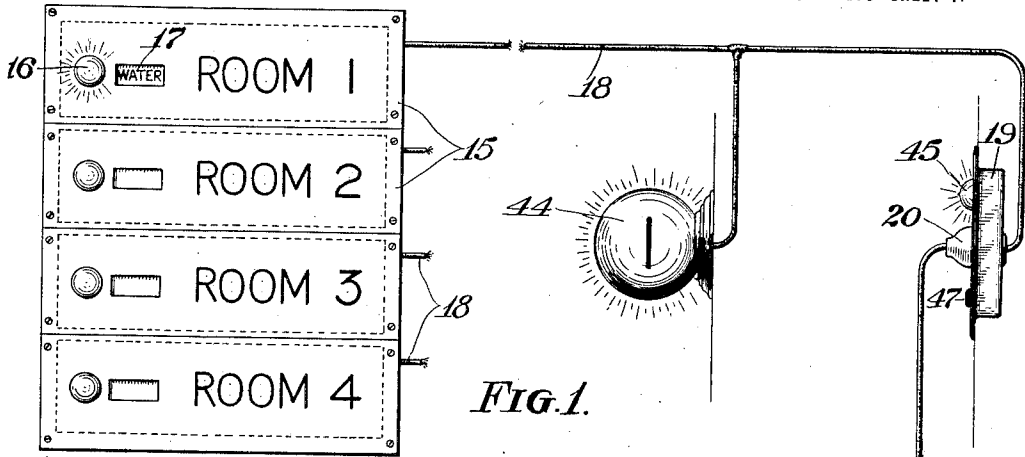

FIG. 1.

FIG. 8.

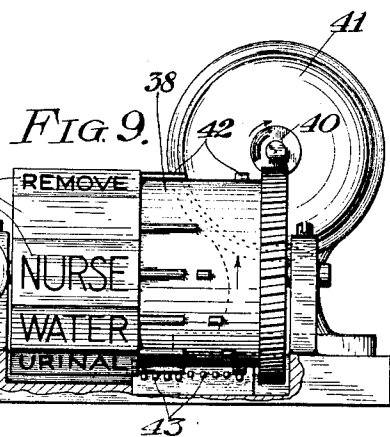
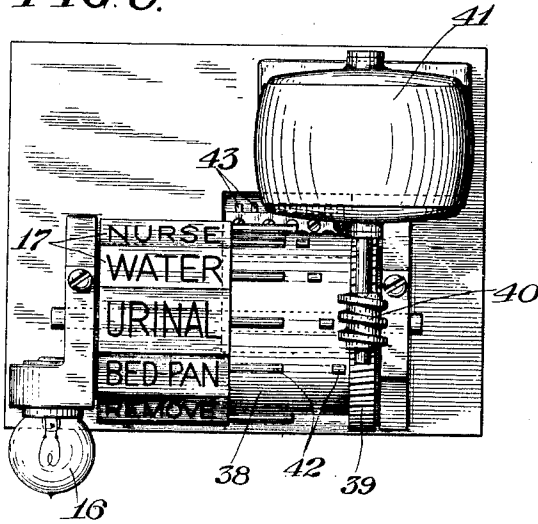

FIG. 9.

WITNESSES.

E. L. Haal
 H. W. Chase

INVENTOR.

By *Bornett L. Bobroff*
R. S. Caldwell
 ATTORNEY.

1,367,583.

Patented Feb. 8, 1921.
 3 SHEETS—SHEET 2.

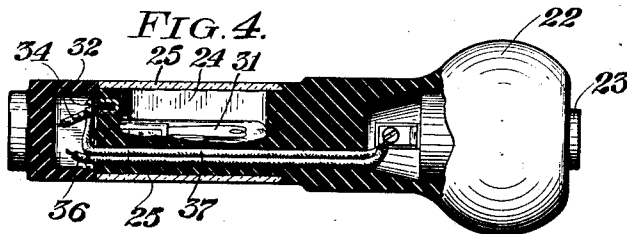
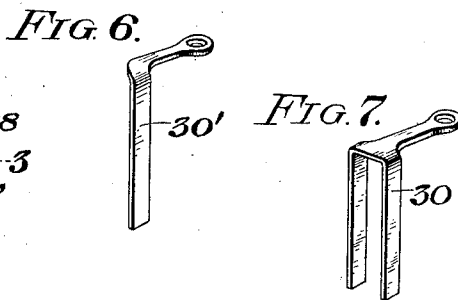
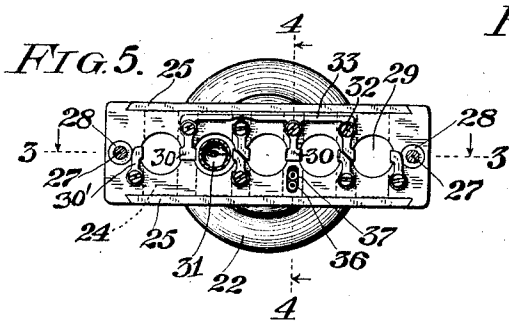
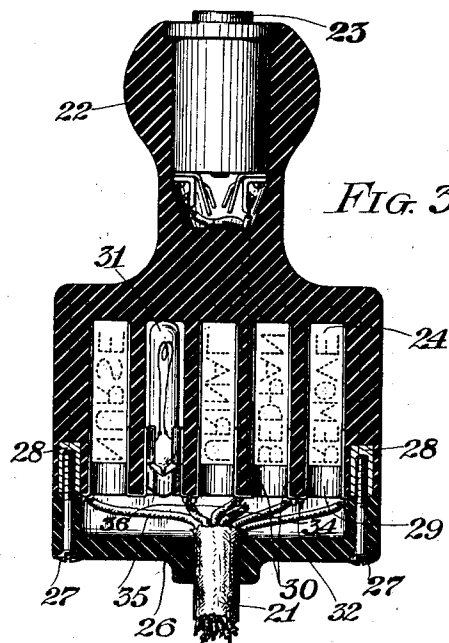
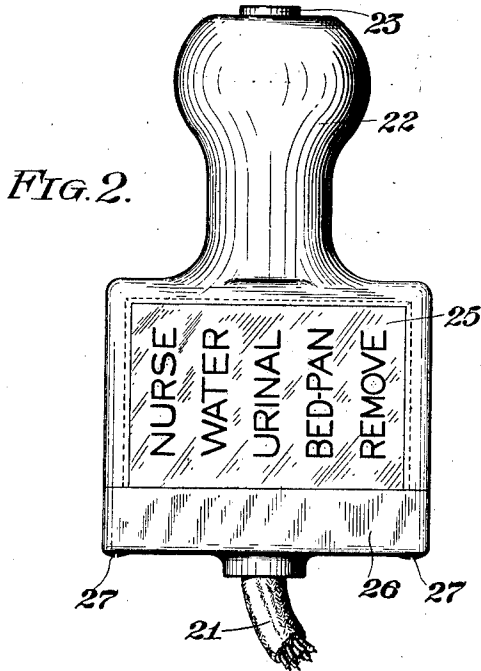

WITNESSES.
 C. F. Haal
 H. A. Chase

INVENTOR.
 By *Borrett L. Bobroff*
R. S. Caldwell
 ATTORNEY.

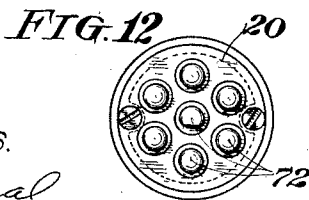
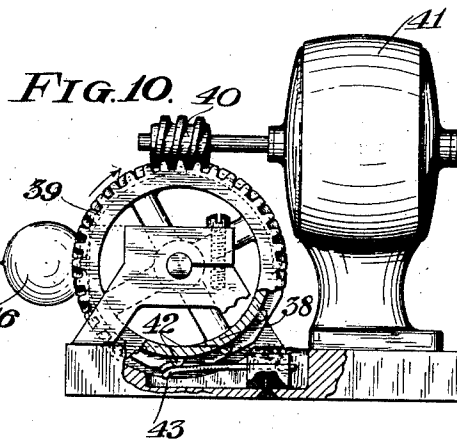
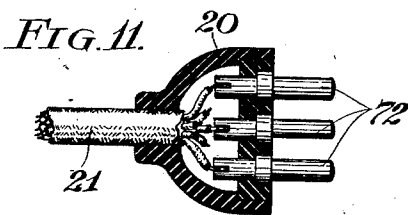
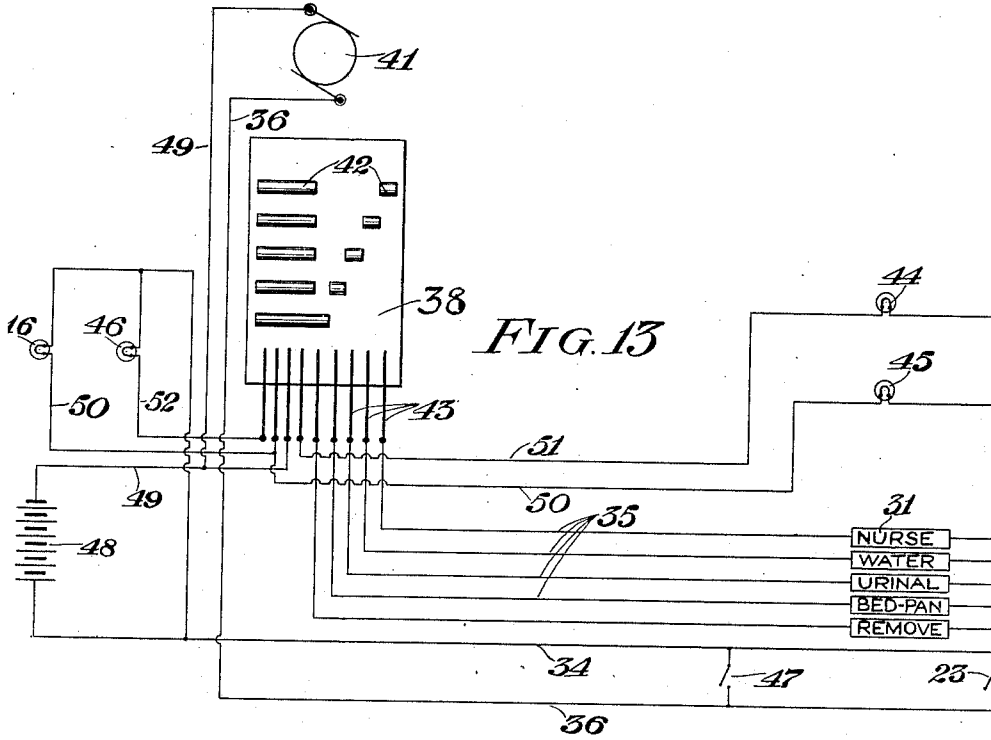

WITNESSES.
E. L. Neal
H. D. Chase

INVENTOR.
Bornett L. Bobroff.
 By *R. S. Caldwell.*
 ATTORNEY.

UNITED STATES PATENT OFFICE.

BORNETT L. BOBROFF, OF MILWAUKEE, WISCONSIN.

SYSTEM FOR SIGNALING.

1,367,583.

Specification of Letters Patent.

Patented Feb. 8, 1921.

Application filed April 2, 1918. Serial No. 226,189.

To all whom it may concern:

Be it known that I, BORNETT L. BOBROFF, a citizen of the United States, and resident of Milwaukee, Milwaukee county, Wisconsin, have invented new and useful Improvements in Systems for Signaling, of which the following is a description, reference being had to the accompanying drawings, which are a part of this specification.

This invention relates to systems for signaling in which any one of a number of signals may be sent for indication on an annunciator. The present invention is particularly adapted for use in hospitals, sanatoriums and the like. However, it is capable of various other uses.

An object of the invention is to provide such a system with a motor driven annunciator adapted to have its annunciator drum turned as long as the transmitting push button remains closed, and adapted in each of its signaling positions to close a circuit indicating at the sending station the signal which is displayed thereby, so that the sender has only to hold the transmitting push button closed until the desired signal is indicated at the sending station, the opening of the transmitting push button at this point causing the annunciator to remain in the position to display the signal so chosen.

Another object of the invention is to provide a signaling system of this character in which the operation of the annunciator not only controls an indicating circuit in the push button holder, but controls indicating lamp circuits to various other points to indicate that a signal has been given at a certain bed in a certain room.

Another object of the invention is to provide means whereby the nurse or attendant may restore the indicator to a non-signaling position on responding to the signal.

Another object of the invention is to perfect details of construction of the mechanism involved in the signaling system.

With the above and other objects in view the invention consists in the signaling system, its parts and combinations of parts as herein claimed and all equivalents.

Referring to the accompanying drawings in which like characters of reference indicate the same parts in different views:

Figure 1 is a diagrammatic illustration

of a signaling system embodying the present invention;

Fig. 2 is a detail view of the push button holder;

Fig. 3 is a central sectional view thereof on the plane of line 3—3 of Fig. 5;

Fig. 4 is a longitudinal sectional view thereof on the plane of line 4—4 of Fig. 5;

Fig. 5 is an end view with the cap removed;

Figs. 6 and 7 are perspective views of indicator lamp socket terminals;

Fig. 8 is a plan view of one of the motor driven annunciators;

Fig. 9 is a front view thereof with the base sectioned showing engagement of contacts;

Fig. 10 is an end view thereof with parts sectioned for the same purpose;

Fig. 11 is a sectional view of the attachment plug for the wall socket;

Fig. 12 is an end view thereof; and,

Fig. 13 is a diagram of circuit connections of one annunciator unit.

In these drawings 15 indicates a row of annunciator units of which there is one for each room, or one for each bed where there is more than one bed in a room. These annunciators may be designated with the room numbers or the bed numbers and are provided with signal lamps 16 and openings through which name faces 17 are shown whenever signals are given, such name faces exhibiting through the openings in the annunciator fronts the name of whatever is signaled for by the patient. Each annunciator unit is connected by a cable 18 with an outlet box 19 in the wall of the room indicated on the annunciator front or close to the bed so indicated. An attachment plug 20 shown in detail in Figs. 11 and 12 is adapted to fit in a suitable socket provided for it in the outlet box 19 to establish connection between the various wires of the cable 18 and corresponding wires in a flexible cable extension 21, the arrangement of the projecting plug terminals 72 being such that the plug may only fit in the socket in the one position in which the proper connections are established. A push button holder 22, preferably in the form of a pear push button with a flat indicating portion as shown, is attached to the end of the cable extension 21 and has a push button 23 at its

end and a row of indicating lamp slots 24 through it covered by opposite glass plates 25 having the names of the various needs of the patient marked thereon.

5 The push button holder 22 preferably consists of the body portion and a removable cap 26 which is secured thereto by means of screws 27 threaded into bushings 28 embedded in the molded insulating com-
10 position of which the body portion is formed. Each of the slots 24 communicates with a circular opening 29 at the end of the body portion where diametrically
15 opposite lamp sockets for receiving small indicating lamps 31. The lamp terminals 30 may be formed of metal strips bent over and secured to the flat end of the body portion of the push button holder by means of
20 screws 32 threading into insert bushings or studs.

The end of the cable extension 21 passes through a central opening in the cap 26 and its wires are separated and connected with
25 the various terminals. A common connecting strip 33 connects with the two double terminal strips 30 and with one of the single terminal strips 30' so as to form a
30 common connector for one lamp terminal of each socket and one of the wires, wire 34, is connected thereto, while other wires 35 connect with the other terminal strips individually and a wire 36 passes through an
35 opening in the body portion to the push button 23. The other wire 37 from the push button connects with the common connecting strip 33 so that the said wire 34 in connection therewith constitutes a common return
40 for each lamp circuit.

Besides inclosing the wiring connections the cap 26 serves to retain the beveled glass slides 25 in the undercut grooves of the body portion.

45 Each of the indicating lamps 31 with its respective wire 35 and the common return wire forms a separate lighting circuit controlled by the engagement of the spring fingers 43 and the ribs 42 of the contact drum
50 38 of the annunciator unit 15 on which the name faces 17 are formed. This contact drum is suitably mounted to rotate and is provided with a worm gear 39 driven by a worm 40 on the shaft of a motor 41. The
55 motor 41 is operated by closing the push button 23 and serves to slowly rotate the drum 38 to bring the name faces 17 successively in position for display through the opening in the annunciator front. At the
60 same time the turning of the drum causes the operation of the switches controlling the circuits through the indicating lamps 31 in such a way that the circuit will be closed through that lamp 31 which illuminates the
65 name on the push button holder correspond-

ing with the name showing through the opening of the annunciator front. For this purpose the annunciator drum 38 is provided with projecting ribs 42 for engage-
70 ment with spring contact fingers 43 arranged in a row on an insulating support beneath the drum. There is one contact finger for each indicating lamp and others for
75 controlling signal circuits to different parts of the building where it is desired to indicate that a signal has been given. These auxiliary lighting circuits are desired to operate in each signaling position of the annunciator drum and the contact ribs 42 are
80 alike as to that portion necessary for the operation of such circuits. The other portions of the ribs are in stepped relation for causing the indicator lamp 31 to be operated successively. The so-called auxiliary
85 signal lights controlled by the portions of the contact ribs which are common may include the annunciator signal light 16, a room light 44 above the door of the patient's room, a wall box light 45 on the wall
90 box 19, and one or more other lights 46 in the supply room or wherever it is desired to display the signal.

In addition to the push button switch 23 for closing the circuit of motor 41 to set the annunciator in operation, there is another
95 push button switch 47 on the wall plate 19, which is to be pressed by the nurse when responding to the signal to cause the return of the annunciator to a blank position in which there is no name appearing through
100 the opening of the annunciator front plate and in which there is no indicating lamp circuit closed.

In the diagram of Fig. 13 the various parts are as above described and a battery
105 or other source of electrical current supply 48 is shown with one terminal connected with the common return wire 34 and the other terminal connected by a wire 49 with one of the spring contact fingers 43 and
110 with one terminal of the motor 41, the other terminal of which is connected with the wire 36 from push buttons 23 and 47.

In the normal or blank position of the annunciator drum 38 as shown in the diagram,
115 none of the contact fingers 43 are engaged by the contact ribs 42 and consequently none of the lights are burning. When, however, the patient is desirous of attention he presses the push button 23 which closes the circuit
120 through motor 41 causing the annunciator drum to be slowly revolved and bringing the contact ribs 42 successively into engagement with the common contact fingers 43 and also the contact fingers for the respective indi-
125 cating lamps 31. This causes the indicating lamps 31 to flash up one after the other and at the same time lights the lamp 45 on the wall box 19, the lamp 44 at the door of the room, the lamp 16 on the annunciator for
130

that room, and other lamps 46 in other parts of the building. The lighted indicator lamp 31 in the push button holder indicates to the patient the signal which he has caused to be displayed on the annunciator and if that is not the signal desired to be given he merely holds the push button 31 depressed while one signal lamp after the other is lighted until the desired signal is indicated. He then removes his finger from the push button, thus breaking the motor circuit and allowing the drum to remain in that position until the nurse arrives at the patient's bedside and presses the resetting push button 47 to complete the cycle of operation of the drum and restore it to a blank position where no indicating lamp circuits are closed. The nurse knows when the system is restored to blank position by the lamp 45 becoming extinguished.

The wall light 45 and the instrument light 16 which apply to the one transmitting device may have their lead wires 50 connected to the same contact finger 43. The room light 44 which may serve in common for a number of transmitting instruments in the same room or ward requires a separate contact finger with which it is connected by wire 51. Likewise the supply room light and other lights 46 connected by wire 52 require separate contact fingers as they are preferably connected in common with all instruments on the floor.

By means of this invention the patient is enabled to signal at once his desires without necessitating the delay incident to requiring the nurse to go to the bedside of the patient in order to learn what is wanted. Furthermore, the signal as given remains until the signaling system is reset by the nurse at the bedside after responding to the signal. The patient knows just what signal has been given because of the burning of the indicator lamp in the push button holder and it is not necessary for him to learn a code of signals. If he desires to cancel a signal or to change it after it has been given, it is only necessary for him to press the button again and so start the motor operated annunciator drum in operation until the blank position is reached or the desired signal is indicated.

The construction of the push button holder is such that the signal words may be read from either side thereof and the words may be arranged so that they are upright when either face of the push button holder is turned to the front, while the device is held in the same hand, or so that one face reads correctly when the device is held in one hand and the other face when the device is held in the other hand. The push button holder is compact and strong and readily accessible for renewing the lamps when required.

I desire it to be understood that this invention is not limited to any specific form or arrangement of parts except in so far as such limitations are specified in the claims.

What I claim as new and desire to secure by Letters Patent is:

1. In an electrical signaling system, an electric motor, a signaling switch for closing the motor circuit, an annunciator driven by the electric motor for producing signals successively while the motor circuit is closed, indicating circuits controlled by the annunciator for indicating at the place of the signaling switch the signal produced by the annunciator whereby the signaling switch may be opened when the desired signal is produced by the annunciator.

2. In a signaling system, an electric motor, a signal switch at a distance from the motor for controlling the motor circuit, a worm on the motor shaft, an annunciator drum, a worm wheel on the drum meshing with the worm, indicator switches closed by the drum in different positions thereof, and indicating means at the place of the signaling switch controlled by the indicating switches for indicating the signal produced by the annunciator drum in order that the operator may know when to open the signaling switch to stop the motor and the annunciator drum in position to produce the desired signal.

3. In a signaling system, a rotatably mounted annunciator drum having a blank position and positions for showing signals, a motor for slowly rotating the annunciator drum continuously while the motor circuit is closed, a push button holder mounted on a flexible cable, a push button on the push button holder for closing the motor circuit, means on the push button holder operated by the annunciator drum in its various positions for indicating the signal produced by the annunciator drum, and a wall switch for closing the motor circuit to restore the annunciator drum to its blank position.

4. In an electrical signaling system, a push button holder, comprising a flat panel-like portion having a series of recesses in its face, electric lamps seated within the recesses, a covering for the face of the panel portion having signals marked thereon to be indicated by the electric lamps and all capable of being seen in one position of the push button holder, a push button on the push button holder, and means for separately lighting the lamps on the operation of the push button.

5. In an electrical signaling system, a push button holder having a flexible cable connection and comprising a flat panel portion provided with transverse openings, indicating lamps within said openings, coverings on opposite faces of the panel portion having signals thereon illuminated by the

electric lamps all signals on either face capable of being seen in one position of the push button holder, a push button on the push button holder, and means for separately lighting the lamps on the operation of the push button.

6. In an electrical signaling system, a push button holder having a flat panel-like portion with a series of slots therethrough, electric lamps within the slots, glass coverings for the opposite faces of the panel portion with signal marks thereon illuminated by the lamps all signal marks on either face capable of being seen in one position of the push button holder, a push button on the holder, and means for separately lighting the lamps on the operation of the push button.

7. In an electrical signaling system, a push button holder having a flat panel portion with a series of slots therethrough, electric lamps fitting within the slots, glass plates fitting within dovetailed grooves on the opposite faces of the panel portion and having signals marked thereon to be illuminated by the lamps, all signals on either face capable of being seen in one position of the pushbutton holder, a push button on

the push button holder, and means for separately lighting the lamps on the operation of the push button.

8. In an electrical signaling system, a push button holder comprising a flat panel-like portion and a cap portion fitting on the end thereof, there being a series of slots through the panel portion and circular openings in the end of the panel portion communicating with the slots, metal terminal strips secured to the end of the panel portion and extending into the openings, electric lamps seated in the openings and contacting with the terminal strips, cover plates of translucent material slidably fitting in undercut grooves on opposite faces of the panel portion and held in place by the cap portion, said cover plates having signal marks thereon illuminated by the electric lamps, a push button on the push button holder, and means for separately lighting the lamps on the operation of the push button.

In testimony whereof, I affix my signature, in presence of two witnesses.

BORNETT L. BOBROFF.

Witnesses:

R. S. C. CALDWELL,
H. D. CHASE.